



Kleenpak™ Sterile Disconnecter



For Convenient and Secure Sterile Disconnection of Flexible Tubing

The Kleenpak sterile disconnecter provides an easy to use, secure method for the sterile disconnection of flexible tubing assemblies even in an uncontrolled environment. It can also be used in processes involving single-use systems as well as hybrid systems. The disconnecter maintains sterility of the fluid path before and after disconnection.

The disconnecter consists of a joined male and female unit, to fit tubing with 13 mm (½ in.) ID. Kleenpak sterile disconnectors can either be autoclaved up to 130 °C or gamma irradiated up to 50 kGy.

The Kleenpak sterile disconnecter brings a major improvement to single-use technology in aseptic processing. It can be used at all stages of the process, but will be particularly valuable in upstream and formulation and filling, where both ease of use and sterility assurance are critical. Pall Life Sciences can engineer and manufacture state-of-the-art Allegro™ single-use systems with Kleenpak sterile disconnectors for all these critical applications.

Applications

- ▶ Disconnection after transfer of inocula to fermentors or bioreactors
- ▶ Disconnection after sampling
- ▶ Disconnection of small sterile equipment from large equipment (e.g. bioreactors)
- ▶ Disconnection while handling bulk material in a non sterile environment
- ▶ Disconnection from tank to filling line
- ▶ Disconnection from a disposable system

Benefits

- ▶ Disconnection can be performed in a non-controlled environment without compromising the sterility of the fluid path
- ▶ No capital equipment required
- ▶ Disconnection is performed in seconds
- ▶ Easy to make disconnection – even in cramped environments
- ▶ Microbial control or sterilization by autoclave or gamma irradiation
- ▶ Activation enables a sterile separation
- ▶ Locking mechanism prevents incorrect disassembly
- ▶ Secure permanent disconnection security – cannot be reconnected
- ▶ No flow restrictions as a result of using of the Kleenpak sterile disconnecter

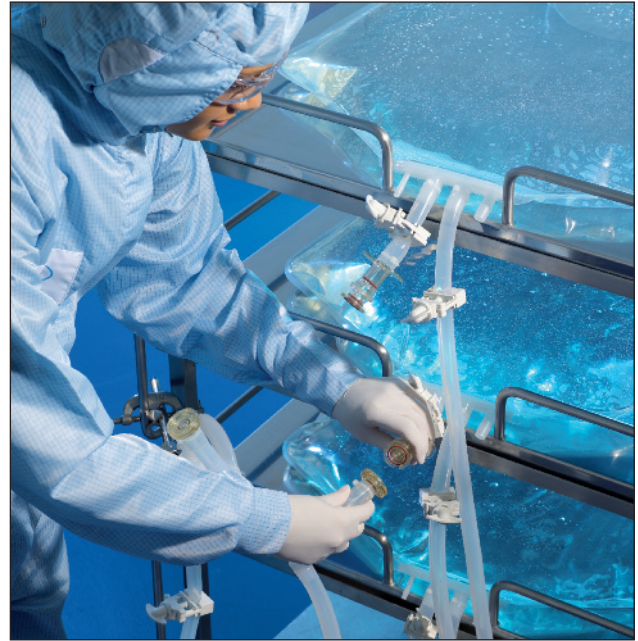

Quality Standards

- ▶ Manufactured under clean room conditions in a controlled environment
- ▶ Manufactured under a Quality Management System certified to ISO9001
- ▶ Supplied with a certificate of test confirming the quality standards and quality control tests performed by Pall (including USP<85> and particulate tests)
- ▶ Validations tests include:
 - Mechanical tests
 - Leak; Burst; Creep rupture and pressure hold test
 - Resistance to freezing storage
 - Functional tests
 - Water flow characteristics
 - Bacterial spore challenge (“soiling”) test
 - Autoclave and gamma resistance
 - Shelf life studies
 - Extractables
 - Absence of BPA (Bisphenol-A) and phthalates
- ▶ The fluid path materials of construction have been tested and meet the requirements of:
 - USP Class VI 121°C - Biological reactivity *in vivo*
 - USP 87 - Biological reactivity *in vitro*
 - USP 661 - Physicochemical tests
- ▶ The fluid path materials of construction do not contain substances derived from animal products (i.e. TSE/BSE risk free)

Sterile Disconnections in Less Than 30 Seconds

Step 1:

Pull (remove) male side anti-actuation collar



Step 2:

Push male section into female section 'CLICK'



Step 3:

Pull (remove) anti-disconnection collar



Step 4:

Twist to separate the two sections



Technical Specifications

Materials of Construction

Main body	Polysulfone
Male side plunger	Polysulfone
Female side connector	Polysulfone
Poppet valve	Polysulfone
O-rings	Silicone
Anti-actuation collar	Thermoplastic elastomer
Anti-disconnection collar	Thermoplastic elastomer
Female end cover	Polysulfone

Aqueous Extractables (NVR)

Water at 60-65 °C after autoclaving at 130 °C and gamma irradiation of 51.2 kGy	Typically < 1 mg
---	------------------

Sterilization Methods

Gamma irradiation	Maximum 50 kGy
Autoclave	75 minutes at 130 °C

Consult with Pall Life Sciences on sterilization methods

Operating Conditions

Maximum operating pressure and temperature	3 bar at 40 °C
--	----------------

Liquid Flow Characteristics

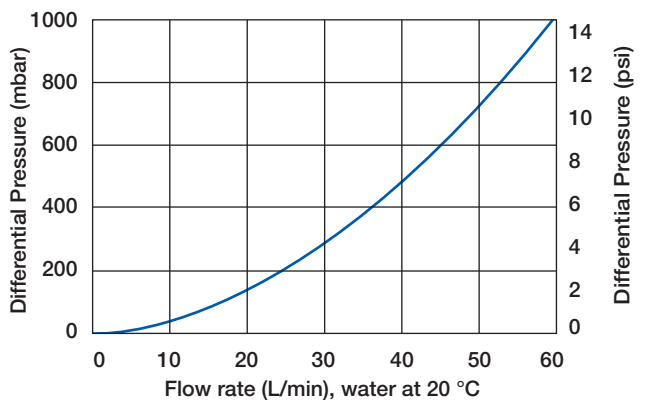

Nominal Dimensions

Description	Dimensions
Total length (A)	121 mm (4.8 in.)
Maximum diameter (B)	61 mm (2.4 in.)
Internal diameter (C)	12 mm (0.5 in.)
Maximum diameter male side (D)	61 mm (2.4 in.)
Maximum length male side once disconnected (E)	85 mm (3.3 in.)
Maximum length female side with female end cover once disconnected (F)	36 mm (1.4 in.)
Maximum diameter of female side with female end cover (G)	36 mm (1.4 in.)

Ordering Information

Part Number	Description	Packaging
KPD011FEC	Female end cover	10 per box, double bagged
KPD01HB6	Kleenpak sterile disconnecter	25 per box, double bagged

Warning: This product is not sold sterile. For use in making sterile disconnections, each disconnecter must be fitted to a closed single-use assembly that has been subjected to a validated sterilizing process.

Schematic Drawings

Full assembly

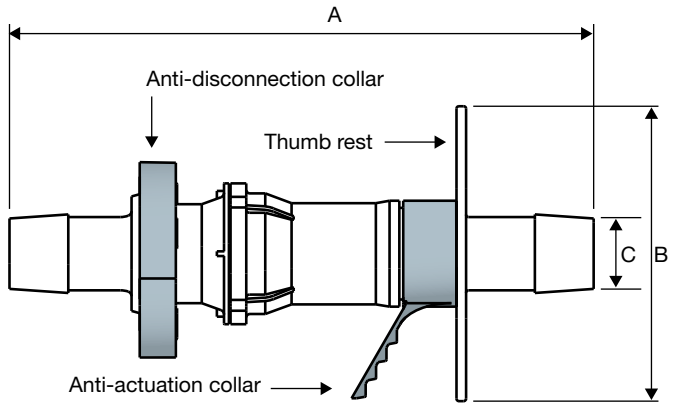

Male side - disconnected

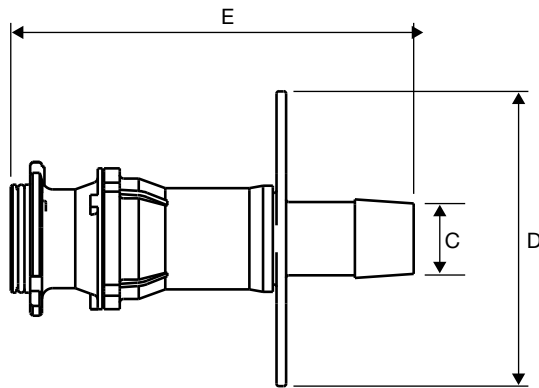

Female side with cap - disconnected

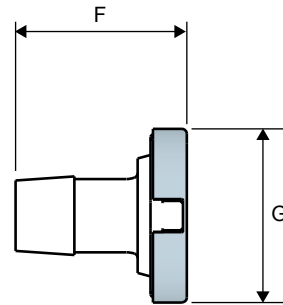

Visit us on the Web at www.pall.com/allegro

E-mail us at allegro@pall.com

International Offices

Pall Corporation has offices and plants throughout the world in locations such as: Argentina, Australia, Austria, Belgium, Brazil, Canada, China, France, Germany, India, Indonesia, Ireland, Italy, Japan, Korea, Malaysia, Mexico, the Netherlands, New Zealand, Norway, Poland, Puerto Rico, Russia, Singapore, South Africa, Spain, Sweden, Switzerland, Taiwan, Thailand, the United Kingdom, the United States, and Venezuela. Distributors in all major industrial areas of the world.

The information provided in this literature was reviewed for accuracy at the time of publication. Product data may be subject to change without notice. For current information consult your local Pall distributor or contact Pall directly.

© 2010, Pall Corporation. Pall, , Allegro, Kleenpak and the Allegro Design are trademarks of Pall Corporation. ® indicates a trademark registered in the USA and TM indicates a common law trademark. Filtration.Separation.Solution.sm is a service mark of Pall Corporation.

Products in this data sheet may be covered by one or more patents including US2010/0007134 A1.



United States

1.800.717.7255 toll free (USA)
1.516.484.5400 phone
1.516.801.9548 fax
biotech@pall.com E-mail

Europe

+41 (0)26 350 53 00 phone
+41 (0)26 350 53 53 fax
LifeSciences.EU@pall.com E-mail